

# AIR AID®

## INTAKE SYSTEMS

Installation Instructions  
Part Number 530-202  
2006-08 Honda Ridgeline  
3.5L

### Packing List:

#1	700-452	Airaid Premium Filter	1
#2	KIT202PC	Panel	1
#3	KITWSTRIP02	Weather Strip 23"	1
	KIT202HP	Hardware & Instructions	1
#4	KIT50C100PHS	M5x10mm Screw	4

### Tools Required For Installation:

Phillips Screwdriver  
Flat Blade Screwdriver

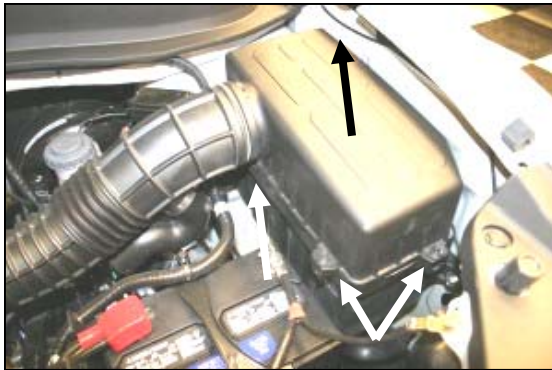
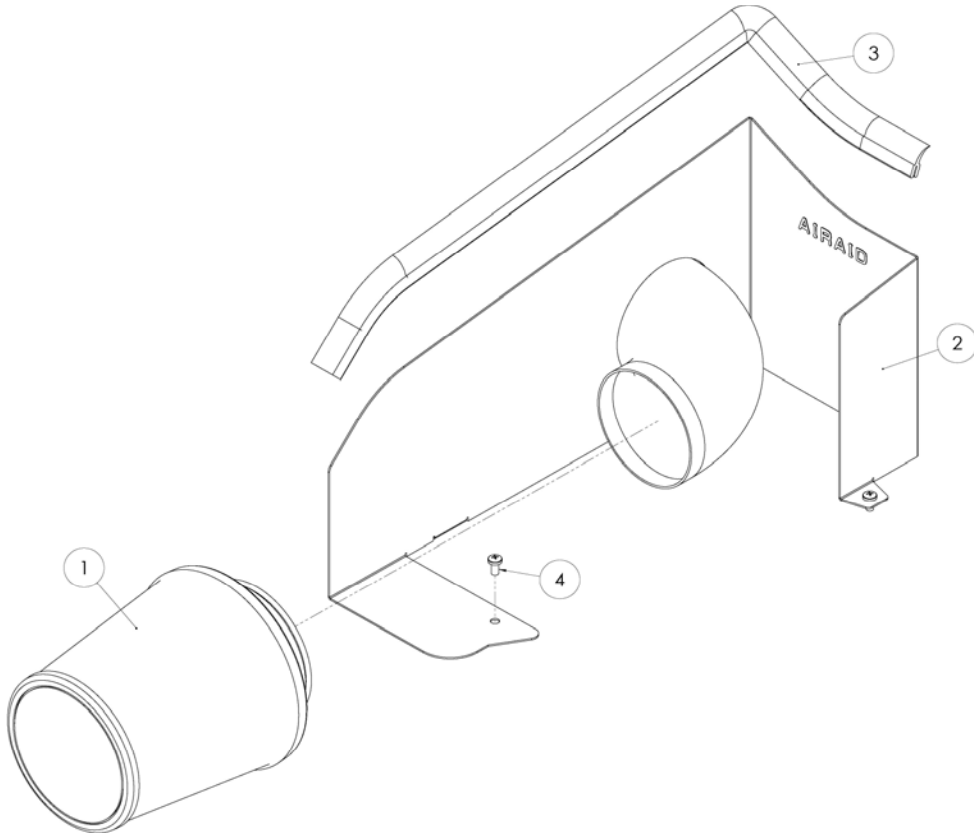

1. **Disconnect negative battery cable.**  
Loosen the 4 factory screws that hold the factory air cleaner lid to the air cleaner base.



2. Remove the factory intake tube from the air cleaner lid by pushing it towards the engine as shown.



3. Remove the factory air cleaner lid from the vehicle.



4. Remove the factory air filter from the vehicle.

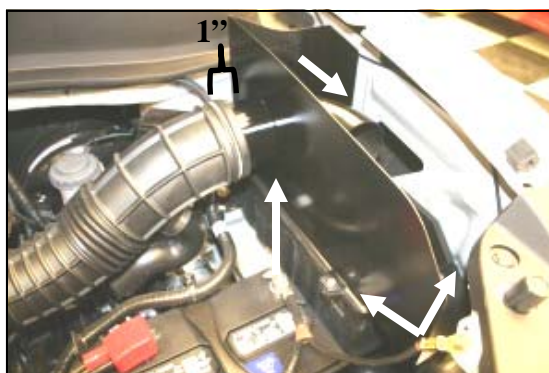

5. Install the Quick Fit Panel (#2) onto the top of the factory air cleaner base. Align the 4 holes, install and tighten the 4 supplied 5mm screws (#4). Carefully slide the factory intake tube onto the Quick Fit Panel Tube. Make sure it is installed at least one inch onto the tube.



6. Install the Airaid Premium Filter (#1) onto the Quick Fit Panel Tube as shown, and tighten the clamp.



7. Install the supplied weather strip (#3) onto the top of the Quick Fit Panel, starting at the left fender, and working your way towards the front of the vehicle.

### 8. Double check your work!

Make sure there is no foreign material in the intake path. Make sure all clamps, hoses, bolts, and screws are tight.

### 9. Reconnect the negative battery cable!

Included with your Airaid Intake System is a sticker with a California Air Resources Board (C.A.R.B.) Executive Order (EO) number. This sticker must be placed in plain view inside of the engine compartment. Failure to do so may prevent you from passing a smog inspection.

**Before!**



**After!**



Thank you for purchasing the Airaid Intake System. Contact Airaid @ (800) 498-6951 8:00 AM - 5:00 PM MST weekdays for questions regarding fit or instructions that are not clear to you. Your Airaid Intake System was carefully inspected and packaged. Check that no parts are missing, or were damaged during shipping. If any parts are missing, contact Airaid. The air filter element is protected from direct exposure to water and debris; care should be taken not to drive through deep water. WATER INGESTION IS THE DRIVERS RESPONSIBILITY! The air filter is reusable and should be cleaned using the Airaid Filter Tune-Up Kit periodically.

## Don't Forget Your AIRAID Filter Tune-Up Kit!



P/N 790-551 Aerosol Spray  
P/N 790-550 Squeeze Spray

Instructions Revision  
Date: 08/23/07