

# AIR AID®

## INTAKE SYSTEMS

**Installation Instructions**  
**Part Number 310-170**  
**2005-10 Jeep Grand Cherokee 5.7L**  
**2006-10 Jeep Grand Cherokee SRT-8**  
**6.1L**



### Packing List:

#1	700-458	Airaid Premium Filter	1
#2	KIT170MAFC	MAF Panel	1
#3	KIT170FPC	Front Panel	1
#4	KITWSTRIP02	Weather Strip 17 1/2"	1
	KIT170HP	Hardware & Instructions	1
#5	KIT6C31MXPPZ	6-32 x 5/16" Screw	4
#6	KIT6NWSAPZ	#6 Flat Washer	4
#7	KIT6CNKEPZ	6-32 Keps Nut	4
#8	KITSNP16M4	Speed Clamp	1
#9	KITELBOW04	1/2" x 90° Elbow	1

### Tools Required For Installation:

5/16" Socket  
 Ratchet & Extension  
 Phillips Screwdriver

**C.A.R.B. E.O. Number Applies Only To  
 Listed Vehicles Up Thru 2008 Models  
 All Others Pending**

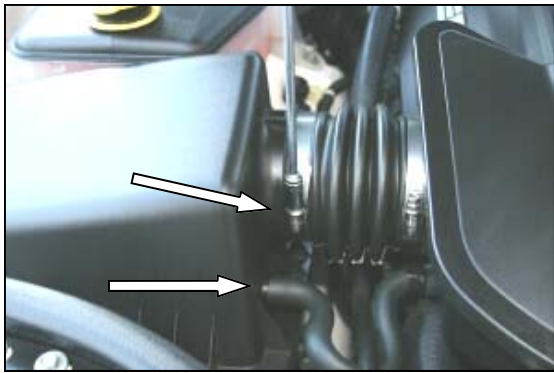
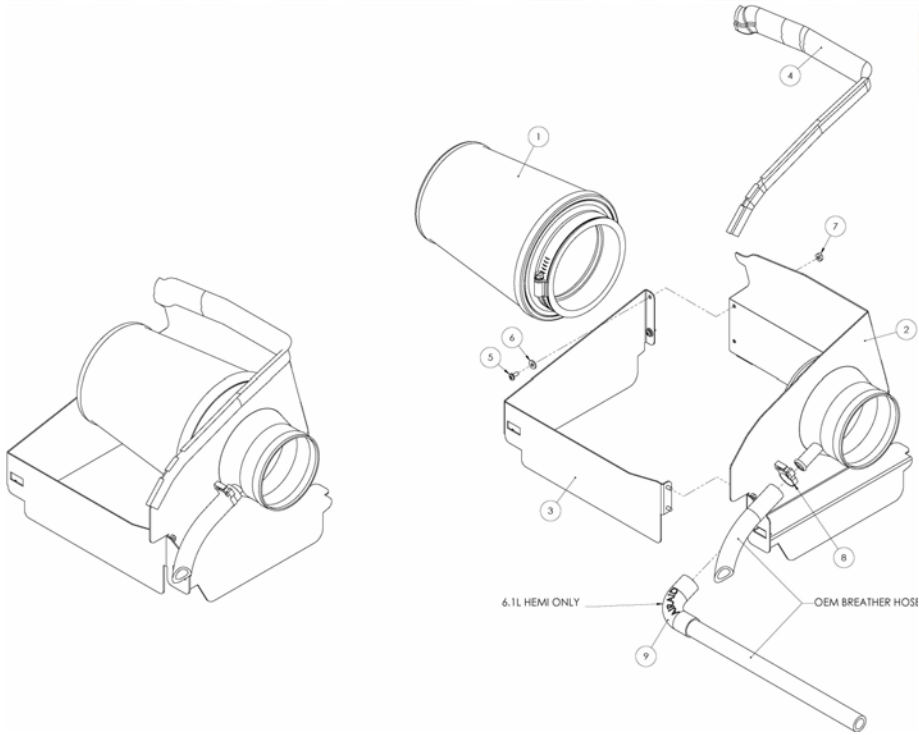

**1. Disconnect the negative battery cable.**  
 Using a 5/16" socket, loosen the hose clamp on the factory airbox lid. Twist and remove the breather hose from the factory airbox lid.

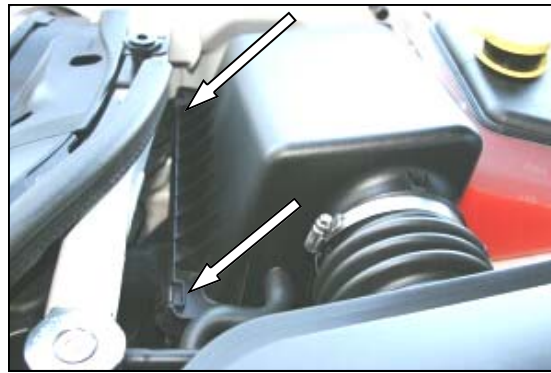

**2.** Unlatch the two clips on the front of the factory airbox lid.



**3.** Remove the factory airbox lid by sliding it forward, and then up and out of the factory intake tube.



**4.** Remove the factory air filter from the airbox base.



**5.** Assemble the Quick Fit Panels (#2, #3) using four 6-32 x 5/16" screws (#5), #6 flat washers (#6), and 6-32 keps nuts (#7).

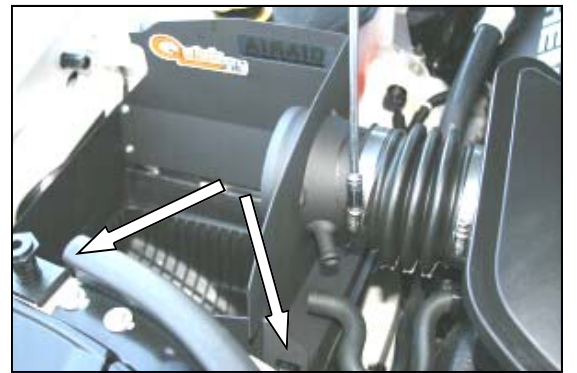

**6.** Install the Quick Fit Panels by sliding the four tabs on the back of the panels into the factory airbox base, and then into the factory intake tube. Relatch the two factory clips into the slots on the front of the Quick Fit Panels. Tighten the hose clamp on the factory intake tube.



**7.** Re-install the breather hose and speed clamp (#8) onto the nipple on the Quick Fit Panel. If you are working on a 6.1L, install the 1/2" x 90° elbow (#9) from the breather hose to the nipple on the Quick Fit Panel.



**8.** Install the Airaid Premium Filter (#1) onto the tube on the Quick Fit Panels, and tighten the clamp.



**9.** Install the weather strip (#4) onto the top of the Quick Fit Panels. (Hint: For ease of installation, start at one end and work your way to the other).

**10. Double check your work!**

Make sure there is no foreign material in the intake path. Make sure all clamps, hoses, bolts, and screws are tight.

**11. Reconnect the negative battery cable!**

Included with your Airaid Intake System is a sticker with a California Air Resources Board (C.A.R.B.) Executive Order (EO) number. This sticker must be placed in plain view inside of the engine compartment. Failure to do so may prevent you from passing a smog inspection.

Thank you for purchasing the Airaid Intake System. Contact Airaid @ (800) 498-6951 8:00 AM - 5:00 PM MST week-days for questions regarding fit or instructions that are not clear to you. Your Airaid Intake System was carefully inspected and packaged. Check that no parts are missing, or were damaged during shipping. If any parts are missing, contact Airaid. The air filter element is protected from direct exposure to water and debris; care should be taken not to drive through deep water. WATER INGESTION IS THE DRIVERS RESPONSIBILITY! The air filter is reusable and should be cleaned using the Airaid Filter Tune-Up Kit periodically.

*Before!*



5.7L Hemi



6.1L Hemi

*After!*



5.7L Hemi



6.1L Hemi

**Don't Forget Your AIRAID Filter Tune-Up Kit!**



P/N 790-551 Aerosol Spray  
P/N 790-550 Squeeze Spray



Instructions Revision  
Date: 12/04/09