

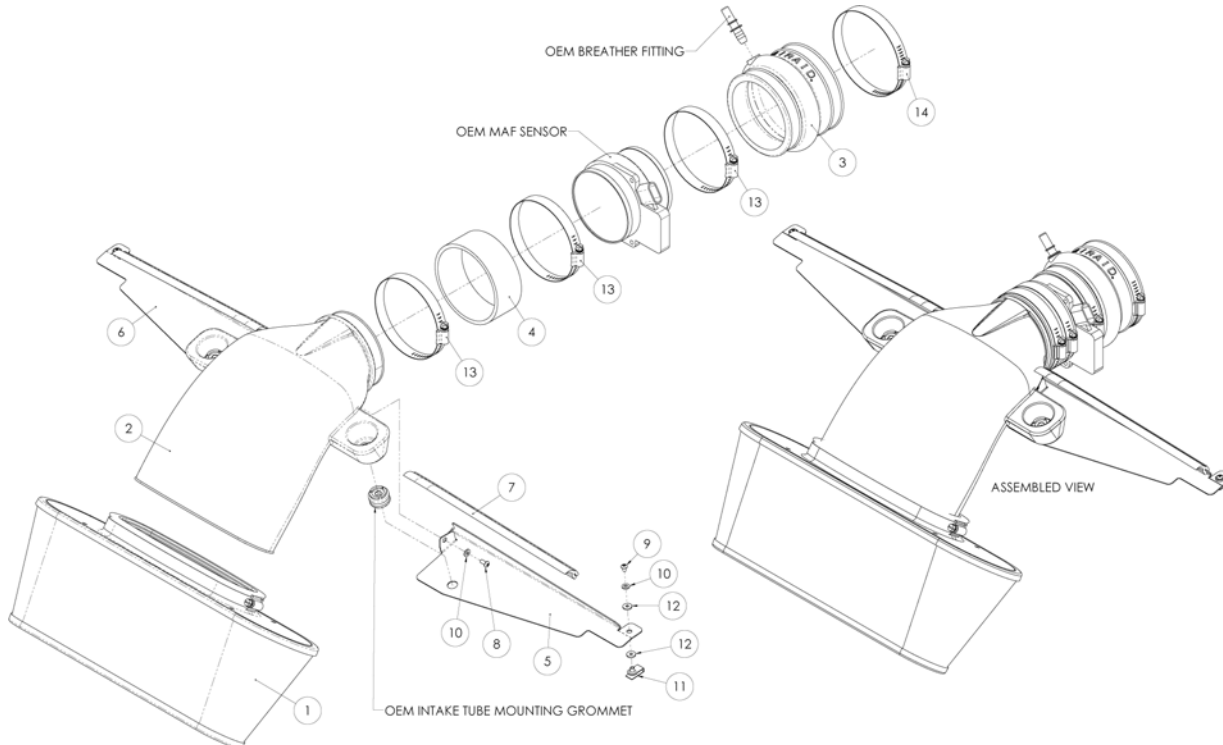

INTAKE SYSTEMS



Installation Instructions Part Number 250-218 2005-07 Chevrolet C-6 Corvette 6.0L V-8

Packing List:

#1	720-475	Airaid Premium Filter	1
#2	KIT218T	Airaid Intake Tube	1
#3	KITHUMPHS19	Urethane Hump Hose	1
#4	KITCOUPLER15	Coupler	1
#5	KIT218DSPC	Drivers Side Air Dam	1
#6	KIT218PSPC	Passenger Side Air Dam	1
#7	KITWSTRIP02	Weather Strip 10 1/2"	2
	KIT218HP	Hardware & Instructions	1
#8	KIT15BHC3038	8-32 x 3/8" Button Head Screw	2
#9	KIT15BHC3016	8-32 x 1/4" Button Head Screw	2
#10	KIT15FW3016	#8 Flat Washer	4
#11	KITNUT02	8-32 Clip Nut	2
#12	KITWASH01	Small Rubber Washer	4
#13	KITHS60	#60 Hose Clamp	3
#14	KITHS64	#64 Hose Clamp	1

Tools Required For Installation:

5/16" Socket
Ratchet & Extension
3/32" Allen Wrench



1. Disconnect negative battery cable.

Push the tab on the factory breather hose and disconnect it from the fitting in the factory coupler. Loosen the three hose clamps on the factory intake tube.

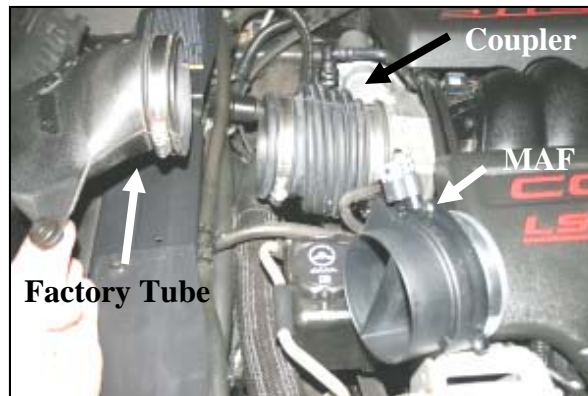

2. Lift the factory intake tube up and remove the Mass Air Flow (MAF) sensor from the coupler and slide it out of the way. Next remove the coupler from the throttlebody, and then remove the factory intake tube and filters from the vehicle as an assembly.



3. Remove the barbed fitting from the factory coupler. It will be reused in step #4.

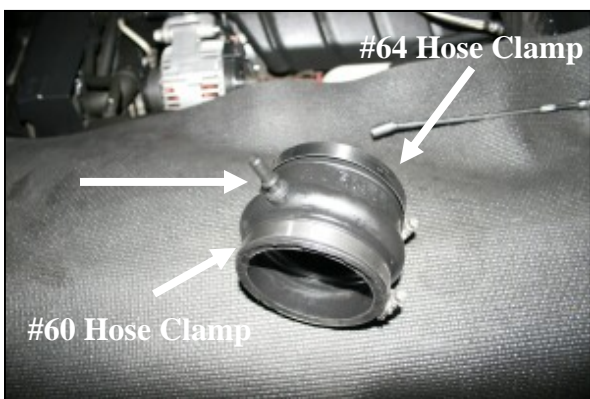

4. Reinstall the barbed fitting removed in step #3 into the Airaid hump hose (#3) as shown. Install one #64 hose clamp (#14) onto the back of the hump hose, and one #60 hose clamp on the front.



5. Remove the two factory grommets from the factory intake tube. They will be reused in step #6.



6. Install the factory grommets removed in step #5 into the Airaid intake tube (#2).



7. Attach the two air dams (#s 5&6) to the Airaid intake tube as shown using two 8-32 x 3/8" screws (#8), and two #8 flat washers (#10). Leave the screws slightly loose for adjustment later. Refer to the line drawing at the top of this page for reference. Next install the supplied coupler (#4) onto the Airaid intake tube as shown using two #60 hose clamps (#13). Tighten only the clamp on the tube.



8. Install the Airaid Premium Filter into the area in front of the radiator. It will be attached to the Airaid intake tube in step #11.

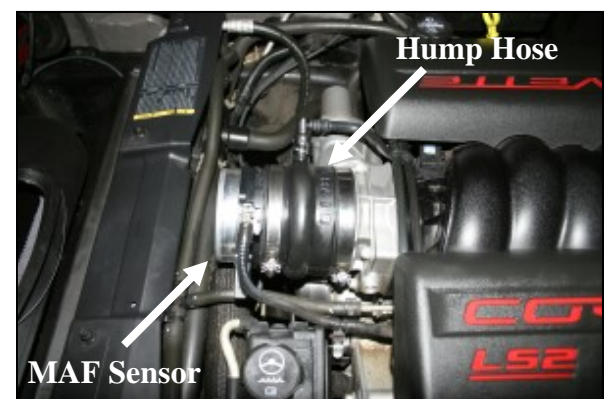

9. Install the hump hose with the #64 hose clamp on the throttlebody. Adjust it so that the breather hose aligns with the barbed fitting, and reconnect the breather. Tighten the hose clamp on the throttlebody. Reinstall the MAF sensor into the hump hose making sure the "Flow" arrow is pointing towards the engine. Tighten the remaining hose clamp.

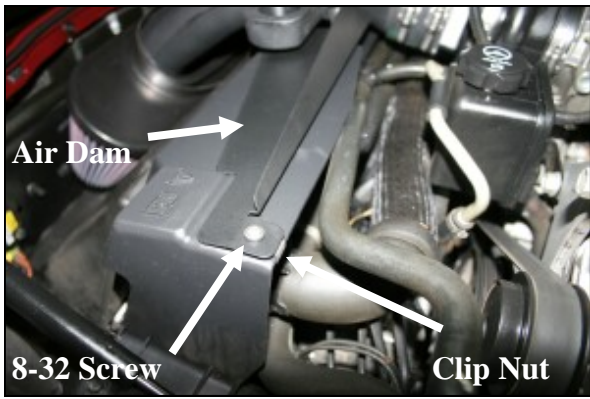

10. Install the Airaid intake tube assembly aligning the grommets over the locating pins on the top of the radiator shroud, and the coupler onto the MAF sensor. Slide one clip nut (#11) onto the radiator shroud with one rubber washer (#12) on the top and then align the air dam over the clip nut. Add one more rubber washer on top of the air dam, and then secure it with one #8 washer (#10) and one 8-32 x 1/4" screw (#9). Repeat the same procedure for the passenger side. Now tighten the two 8-32 screws that hold the air dams to the Airaid intake tube. Refer to the line drawing on the first page for further clarification. Tighten the final hose clamp on the MAF sensor.



11. Install the supplied weather strips (#7) on top of the air dams as shown. Pull the Airaid Premium Filter up and secure it onto the Airaid intake tube with the supplied hose clamp.

12. Double check your work!
Make sure there is no foreign material in the intake path. Make sure all clamps, hoses, bolts, and screws are tight.

13. Reconnect the negative battery cable!

Before!



After!



Thank you for purchasing the Airaid Intake System. Contact Airaid @ (800) 498-6951 8:00 AM - 5:00 PM MST weekdays for questions regarding fit or instructions that are not clear to you. Your Airaid Intake System was carefully inspected and packaged. Check that no parts are missing, or were damaged during shipping. If any parts are missing, contact Airaid. The air filter element is protected from direct exposure to water and debris; care should be taken not to drive through deep water. WATER INGESTION IS THE DRIVERS RESPONSIBILITY! The air filter is reusable and should be cleaned using the Airaid Filter Tune-Up Kit periodically.

Don't Forget Your AIRAID Filter Tune-Up Kit!



P/N 790-551 Aerosol Spray
P/N 790-550 Squeeze Spray

Instructions Revision
Date: 02/19/08