

# AIR AID®

## INTAKE SYSTEMS

**Installation Instructions**  
**Part Number 200-112-1**  
**99-05 Chevrolet/GMC Trucks & SUVs**  
**2006 GMC Sierra & GM SUVs**  
**2007 GMC Sierra "Classic" Trucks**  
**W/ 4.3L, 4.8L, 5.3L, 6.0L, 8.1L**  
**With Low Profile Hood**

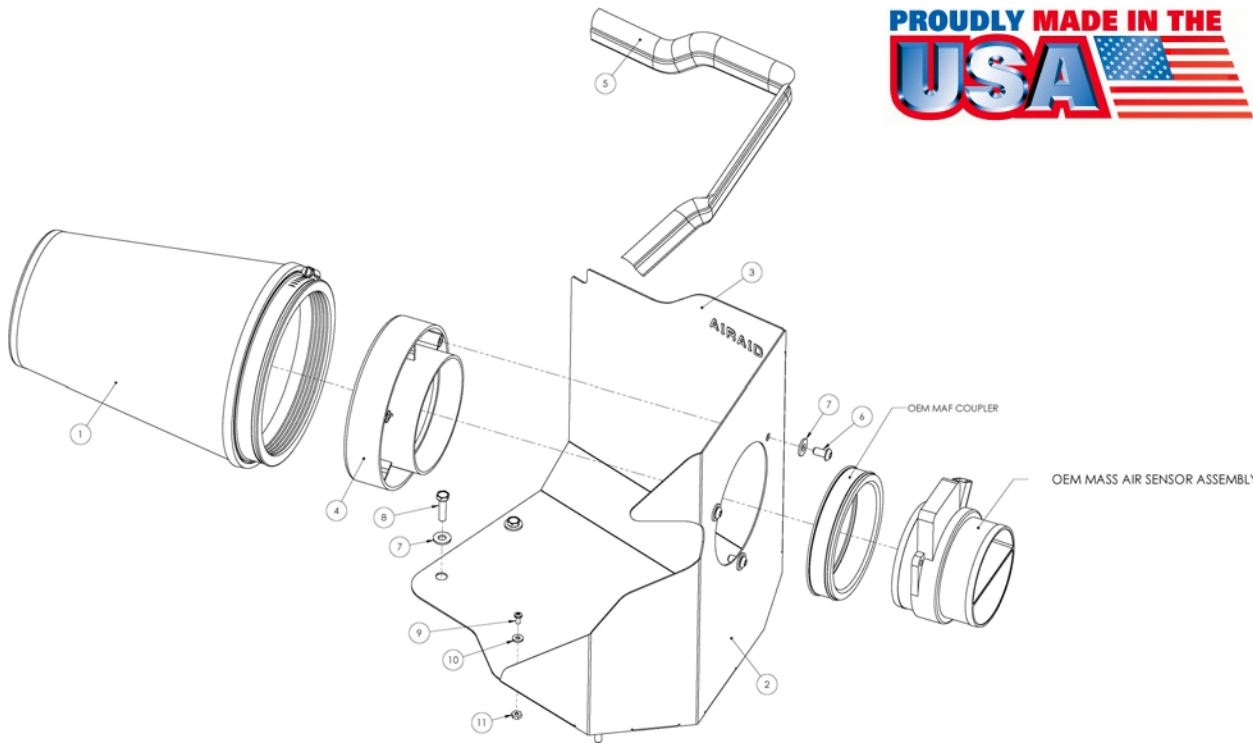

### Packing List:

#1	700-469	Airaid Premium Filter	1
#2	KIT1121MADAC	MAF Panel Coated	1
#3	KIT1121RRDAM	Rear Air Dam Coated	1
#4	KIT1121MAFADA	Black MAF Adapter	1
#5	KITWSTRIP02	Weather Strip 20"	1
	KIT112HP	Hardware & Instructions	1
#6	KIT15DHC3050	1/4"-20x1/2" SS Button Head	3
#7	KIT09FWZ019	1/4" Flat Washer	7
#8	KIT60C250HCS	M6-1x25 Hex Bolt	4
#9	KIT6C31MXPPZ	6-32x 5/16" Screw	5
#10	KIT6NWSAPZ	#6 Flat Washer	5
#11	KIT6CNKEPZ	6-32 Keps Nut	5

### Tools Required For Installation:

5/16", 10mm Socket  
 Ratchet & Extension  
 Phillips Screwdriver  
 5/32" Allen Wrench



**1. Disconnect negative battery cable.**  
 Loosen the hose clamp on the end of the factory intake tube at the Mass Air Sensor.



**2.** Remove the factory tube from the Mass Air Sensor, and slide it out of the way. Next loosen the hose clamp on the Mass Air Sensor.



**3.** Without disconnecting the wiring harness, remove the Mass Air Sensor and coupler from the factory airbox, and set it aside.



**4.** Grab the factory airbox and rock it back and forth, and remove it from the vehicle. It is only held in by grommets, no bolts.

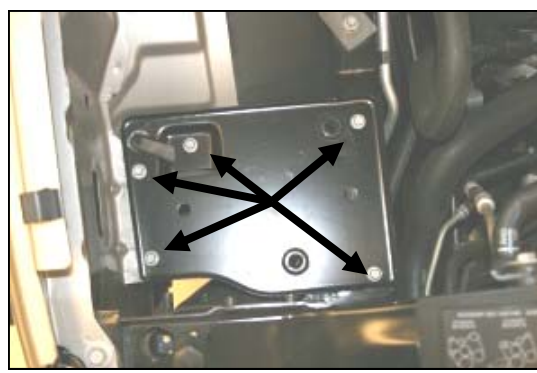

**5.** Remove 5 bolts, and remove the factory airbox mounting plate.



**6.** Assemble the two Cool Air Dam panels (#2) and (#3) using the five supplied screws (#9), washers (#10), and nuts (#11), as shown.

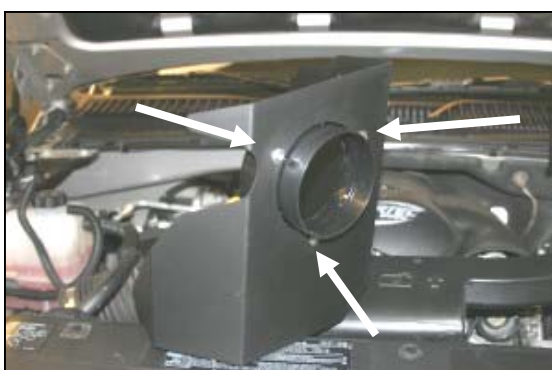

**7.** Install the filter adapter (#4) into the CAD using three button head bolts (#6), and washers (#7).



**8.** Install the assembled CAD in place of the factory airbox using four bolts (#8) and washers (#7). Do not over tighten the bolts.



**9.** Re-install the Mass Air Sensor and coupler onto the air filter adapter (#4), as shown and tighten the hose clamp.



**10. Re-connect the factory intake tube to the Mass Air Sensor, and tighten the hose clamp.**



**11. Install the Airaid Premium Filter (#1) onto the filter adapter (#4), and tighten the hose clamp. Next install the weather strip (#5) onto the top of the CAD as shown. For ease of installation start at the fender, and work towards the radiator.**

**12. Double check your work!**

Make sure there is no foreign material in the intake path. Make sure all clamps, hoses, bolts, and screws are tight.

**13. Reconnect the negative battery cable!**

Included with your Airaid Intake System is a sticker with a California Air Resources Board (C.A.R.B.) Executive Order (EO) number. This sticker must be placed in plain view inside of the engine compartment. Failure to do so may prevent you from passing a smog inspection.

***Before!***



***After!***



Thank you for purchasing the Airaid Intake System. Contact Airaid @ (800) 498-6951 8:00 AM - 5:00 PM MST weekdays for questions regarding fit or instructions that are not clear to you. Your Airaid Intake System was carefully inspected and packaged. Check that no parts are missing, or were damaged during shipping. If any parts are missing, contact Airaid. The air filter element is protected from direct exposure to water and debris; care should be taken not to drive through deep water. WATER INGESTION IS THE DRIVERS RESPONSIBILITY! The air filter is reusable and should be cleaned using the Airaid Filter Tune-Up Kit periodically.

**Don't Forget Your AIRAID Filter Tune-Up Kit!**



**P/N 790-551 Aerosol Spray  
P/N 790-550 Squeeze Spray**



Instructions Revision  
Date: 11/06/07